

Central Monitoring System CGVision

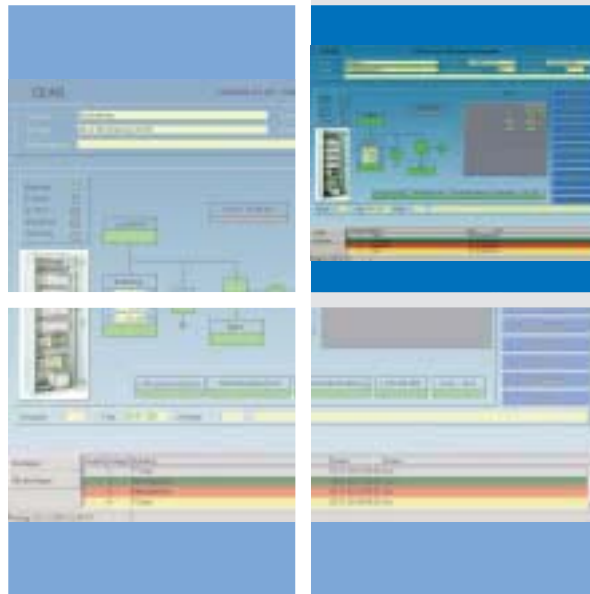

Fields of Application for the Central Monitoring System CGVision

Application Example:

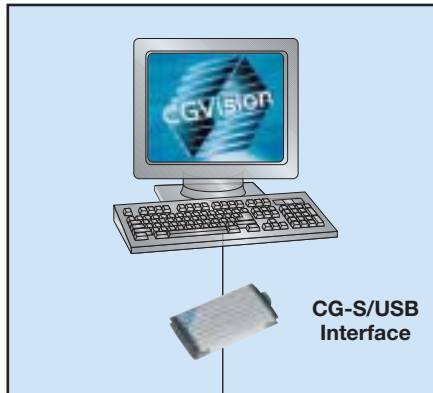

For every single emergency lighting project the appropriate central monitoring station

Statutory regulations stipulate the regular check of emergency systems such as emergency lighting systems. Depending on the size of the emergency lighting plant, it is useful to provide for a central automatic monitoring station. CEAG offers the appropriate monitoring concept for each emergency lighting project.

Systems with automatic individual monitoring

All functions of the luminaire are automatically monitored and controlled by a micro-controller.

The prescribed tests such as the function test which is to ensure the emergency lighting function of the luminaires, or the duration test which checks the battery capacity, are performed fully automatically. The test results are clearly visible on the central monitoring station. Thus, the user saves the time-consuming, manual check of the luminaires and emergency lighting systems.

CEWA GUARD Monitored throughout to the last luminaire

A trouble-free operating system is the prerequisite for the central monitoring of a emergency lighting system. Environmental influences such as varying ambient temperatures or continuously changing power consumption values of the individual luminaires after a prolonged operation must not affect the reliability of the central monitoring station. The CEWA GUARD monitoring concept focuses on the operativeness of each emergency luminaire. The individual monitoring.

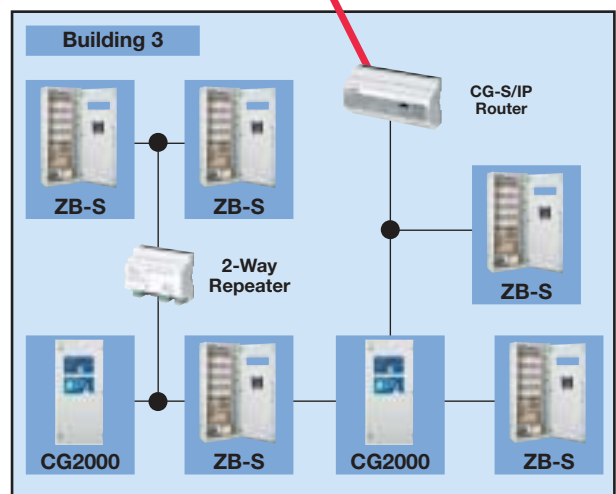
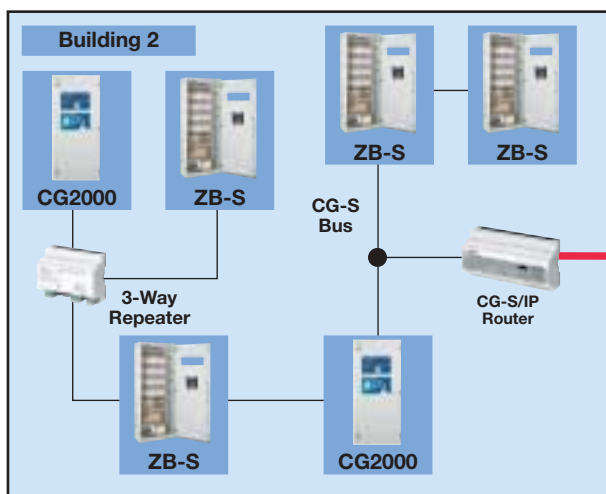
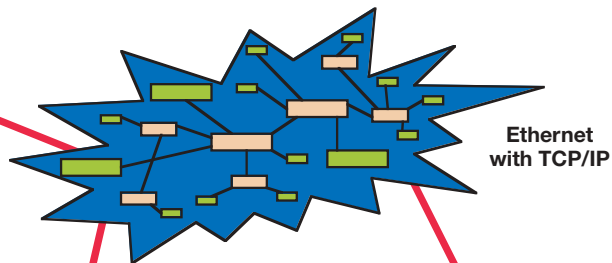
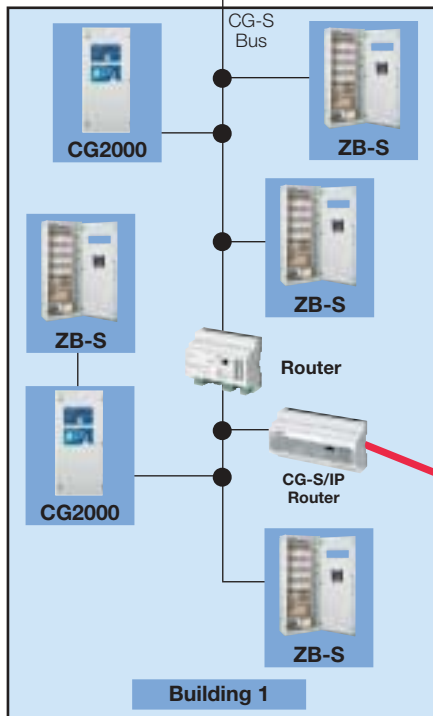

CGVision Advantages



The intelligent solution of the monitoring of emergency lighting

The larger and more complex the office, hotel and industrial buildings are, the higher are the requirements on a present-day and economically efficient monitoring of the emergency lighting.

The CGVision software copes with these requirements in an ideal manner.

Thus, an elaborate manual troubleshooting and checking of each individual luminaire belong to the past. All system-related data will be stored for a period of two years.

After events like mains failures, emergency lighting malfunctions etc. the data can easily be printed out on the available printer and selected by functions.

As well, all connected emergency lighting systems can be programmed and configured via CGVision.



Everything automatically under control

The CGVision controls all connected emergency lighting systems and luminaires based on the latest visualisation software.

The specified daily checks of the emergency lighting are performed automatically.

There is nothing simpler and safer.

The following pages explicitly explain how to locate faulty luminaires.



Up to 480 units/substations simply pratable in 15 groups of 32 devices/units each can be connected to the CGVision via a screened 2-wire cable. Longer distances for peripheral systems can easily be bridged via Ethernet.

Thereby it is possible to individually check the operational state of all connected emergency luminaires and to visualise the test results centrally.

Without time-consuming check patrols!



CGVision Exemplary Representation of Failures

Each emergency luminaire is important. It protects life.

- The failure of a luminaire is indicated as „Failure“ in the **main group output line** and as „Emergency failure“ in the alarmline.



Effortless and reliable localization of each failure

- The next picture shows the circuit module. The circuit with the defective luminaires is marked in red.



- In the **system group output line** you get the information in which cover/substation the failure occurs.



- By choosing the circuit the exact location and the programmed switching mode of the luminaire are displayed in plain text.



- In the **device output line** occurs the localization of the circuit module in which defective luminaires arise.



- For an optimum orientation the option "building layout programming" allows to show the luminaires in the building layout with coloured status display.



CGVision Monitoring and Programming Software



The central monitoring

Each emergency luminaire is important! It protects life and health. Should the general lighting fail, only a emergency lighting system that is fully operational, will provide optimum protection. Depending on the nature of the premises, e. g. staircases without natural light, the accident risk is very high, when only one emergency luminaire fails. For that reason, a continual check of the emergency lighting systems is legally specified. By means of the CGVision monitoring and programming software, the user can easily pull menu-driven all system information and program functions. In addition, the CGVision automatically performs also the specified daily check of the emergency lighting's operativeness. Malfunctions of the luminaires are displayed on the monitor, including the indication of the exact location. Thereby, fault tracing and elimination are considerably simplified. That saves time and money!

- Easy to handle by the user
- Menu-driven pulling of system information
- Automatic check of the emergency lighting
- Indication of the exact location
- Simple failure analysis savings in time and cost
- Continuous availability of all system-related data

CGVision Monitoring and Programming Software



CG-S/USB-Interfacebox



EGA/RS232 Interfacebox



EGA/PC-Interface-2



RS232/USB Converter fourfold

CGVision

Monitoring and Programming software

System conditions for Standard-PC

Operating System	Windows XP Professional or Windows 2000
Processor	at least 2 GHz
Main storage	at least 1024 MB RAM
Hard disc	at least 80 GB
Graphic card	at least 128 MB
Drives	CD-ROM
Monitor	17"
Mouse, keyboard	1 x
USB-Port	1 x unassigned
Parallel Port	1 x unassigned

Ordering details PC-Software

Type	Scope of delivery	Order No.
CGVision „Basic version“ with CG-S/USB-Box	PC-Software on CD incl. CG-S/USB Interfacebox	4 0071 347 385
CGVision „Basic version“	PC-Software on CD	4 0071 347 391

Ordering details PC-Hardware

Type	Scope of delivery	Order No.
PC-System	PC-Miditower with AMD-Prozessor, incl. keyboard, optical mouse and operating system (Windows XP Professional)	4 0071 347 144
17"-TFT	17"-TFT display, TCO03	4 0071 347 155
CG-S/USB-Interface	CG-S/USB-Interfacebox in build-up housing	4 0071 347 137
EGA/RS232-Interface ¹⁾	EGA/RS232 Interfacebox for 32 device max., 1 Line, in build-up housing	4 0071 346 450
EGA/PC-Interface-2	EGA/PC-Interface for 64 devices max. on 2 lines, in DIN-rail housing	4 0071 360 040
EGA/PC-Interface connection box fourfold	EGA/PC-Interface connection box incl. mains adapter, for 128 devices max. on 4 lines, in build-up housing	4 0071 347 821
Quad RS232 Interface Card for PC	Quad RS232 Interface Card for PCI Slot with four COM-Ports	4 0071 347 140
RS232/USB converter fourfold	RS232/USB converter for 4 EGA-lines max. via RS232 to USB for connection to PC	4 0071 347 775
I/O Interface connection box fourfold for CGVision	I/O-Modul incl. mains adapter 24 V/1 A in build-up housing to visualise external devices on CGVision	4 0071 360 025
F3-Interface	I/O-Module for the connection of a F3-remote indication with its functions to CGVision	4 0071 347 138

¹⁾ Per EGA-Line one EGA/RS232-Interfacebox each is necessary.

CGVision Monitoring and Programming Software



USB-Dongle for licence on CGVision



2-Way-Repeater



2-Way-Router



CG-S/IP-Router



CG-S/IP-Connection box



CG-S/IP-Interface

Ordering details Dongle

Type	Scope of delivery	Version	Order No.
CGVision „EGA-Lines“	Licence incl. Dongle for the visualisation of EGA-Lines on CGVision	Parallelport USB	4 0071 347 150 4 0071 347 930
CGVision „building layout programming“	Licence incl. Dongle for building layout programming on CGVision	Parallelport USB	4 0071 347 790 4 0071 347 931
CGVision „Combi Licence“	Combi-Licence incl. Dongle for EGA-Lines and building layout programming on CGVision	Parallelport USB	4 0071 347 791 4 0071 347 932

Ordering details Netzwerkkomponenten

Type	Scope of delivery	Order No.
2-Way Repeater for CG-S Bus	2-Way Repeater for CG-S Bus, for DIN-rail mounting	4 0071 347 143
4-Way Repeater for CG-S Bus	4-Way Repeater for CG-S Bus, for DIN-rail mounting	4 0071 070 583
Router for CG-S Bus	2-Way-Router for CG-S Bus, for DIN-rail mounting	4 0071 347 142
CG-S/IP Router	CG-S/IP Router to connect CG-S Bus and Ethernet, for DIN-rail mounting	4 0071 347 590
CG-S/IP connection box	CG-S/IP-connection box incl. CG-S/IP-Router and mains adapter 24 V/1 A in build-up housing	4 0071 347 592
CG-S/IP Interface	CG-S/IP-Interface USB-Dongle for direct LAN-access on CG-S/IP-Router	4 0071 347 950
EGA/COM-Server	EGA/COM-Server for the connection of EGA-Bus and Ethernet for DIN-rail mounting	4 0071 347 591
EGA/IP-connection box	EGA/IP-connection box. incl. EGA/COM-Server and mains adapter 24 V/1 A in build-up housing	4 0071 347 593
Mains adapter 24 V/1A DC	Mains adapter 24 V/1 A DC for DIN-rail mounting	4 0064 070 421

7

CGVision

Application Examples for Networks

CGVision with CG-S Bus

Without Router/Repeater

Characteristics:

- up to 63 emergency light devices CG2000 and ZB-S
- all topologies possible
- mixed bus operation possible (ZB-S/CG2000)
- recommended cable: JY (St) Y 2 x 2 x 0.8
- line topology: max. 900 m
- free topology: max. 320 m – between 2 nodes max. 500 m – total cable distance

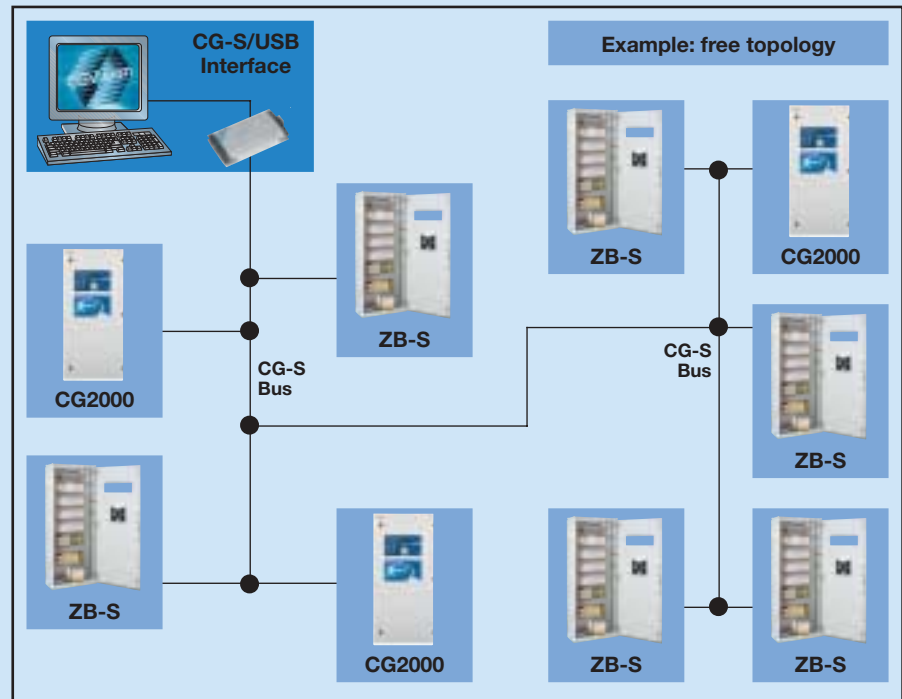

With >1 Router/Repeater

Characteristics:

- up to 480 emergency light devices CG2000 and ZB-S
- up to 63 emergency light devices CG2000 and ZB-S (per Segment)
- Router and Repeater alternately
- Router/Repeater need 24 V-supply
- all topologies possible
- mixed bus operation (ZB-S/CG2000) possible
- recommended cable: JY (St) Y 2 x 2 x 0.8
- line topology: max. 900 m (per Segment)
- free topology: max. 320 m – between 2 nodes (per Segment) max. 500 m – total cable distance (per Segment)

CGVision with CG-S Bus

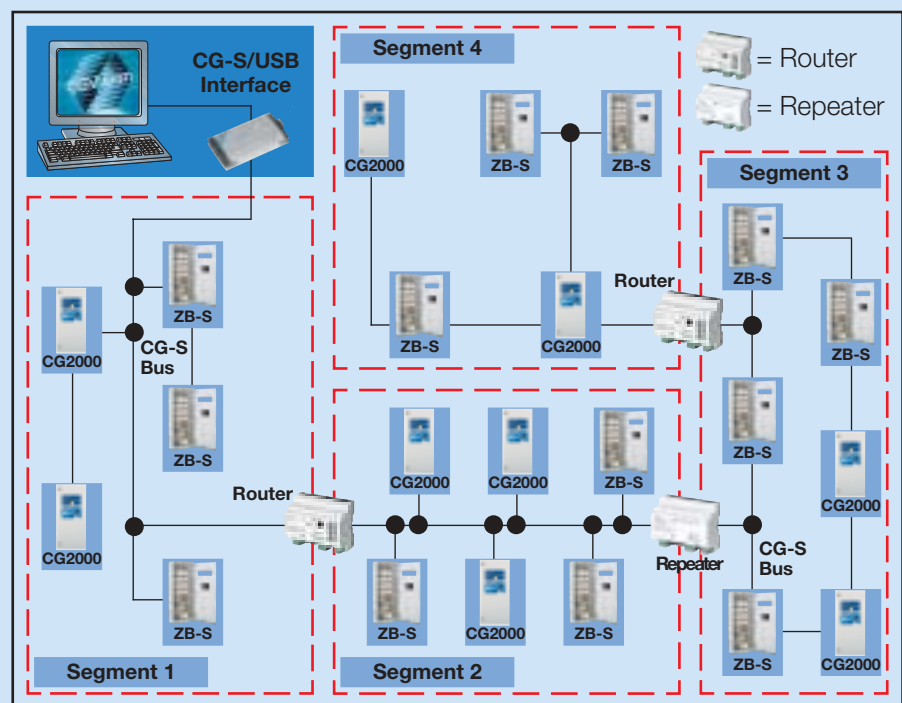

CGVision

Application Examples for Networks

Characteristics:

- up to 480 emergency light devices CG2000 and ZB-S at CGVision
- up to 63 emergency light devices CG2000 and ZB-S per LON-IP segment without Router/Repeater
- max. 20 pieces CG-S/IP Router possible
- CG-S/IP Router need 24 V/DC supply
- all topologies possible
- mixed bus operation (ZB-S/CG2000) possible
- recommended cable: JY (St) Y 2 x 2 x 0.8
- line topology: max. 900 m (per segment)
- free topology: max. 320 m – between 2 nodes (per segment)
max. 500 m – total cable distance (per segment)
- max. Ethernet distances: at site

CGVision with CG-S Bus via Ethernet

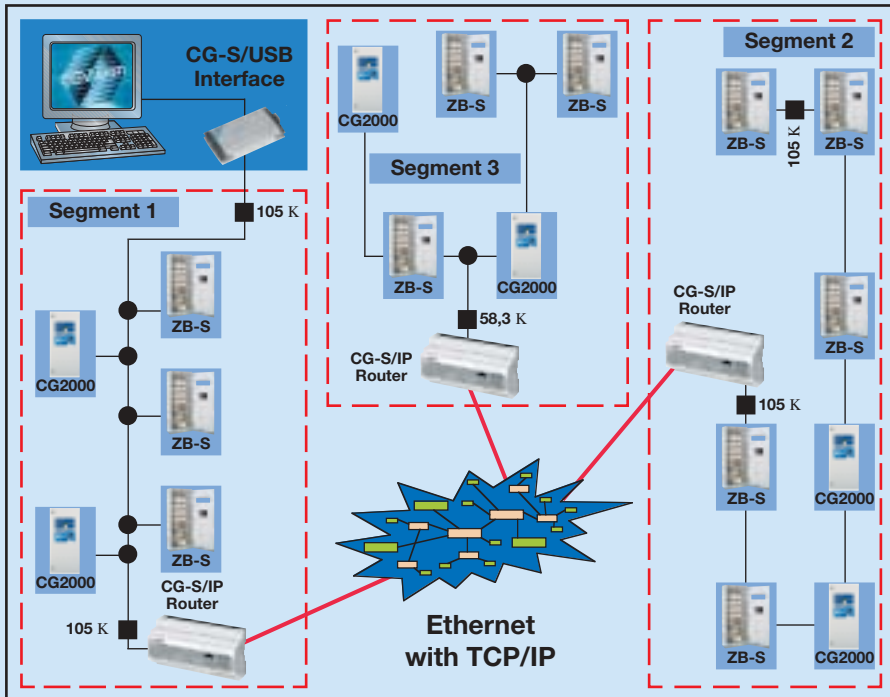

7

Characteristics:

- The CG-S/USB-Interface Box and the CG-S/IP-Router are not necessary for CGVision!
- up to 480 emergency light devices CG2000 and ZB-S at CGVision
- up to 63 emergency light devices CG2000 and ZB-S per LON-IP-segment without Router/Repeater
- max. 20 pieces CG-S/IP Router possible
- CG-S/IP Router needs 24 V/DC supply
- all topologies possible
- mixed bus operation (ZB-S/CG2000) possible
- recommended cable: JY (St) Y 2 x 2 x 0.8
- line topology: max. 900 m (per segment)
- free topology: max. 320 m – between 2 nodes (per segment)
max. 500 m – total cable distance (per Segment)
- max. Ethernet distances: at site

CGVision with CG-S Bus via Ethernet

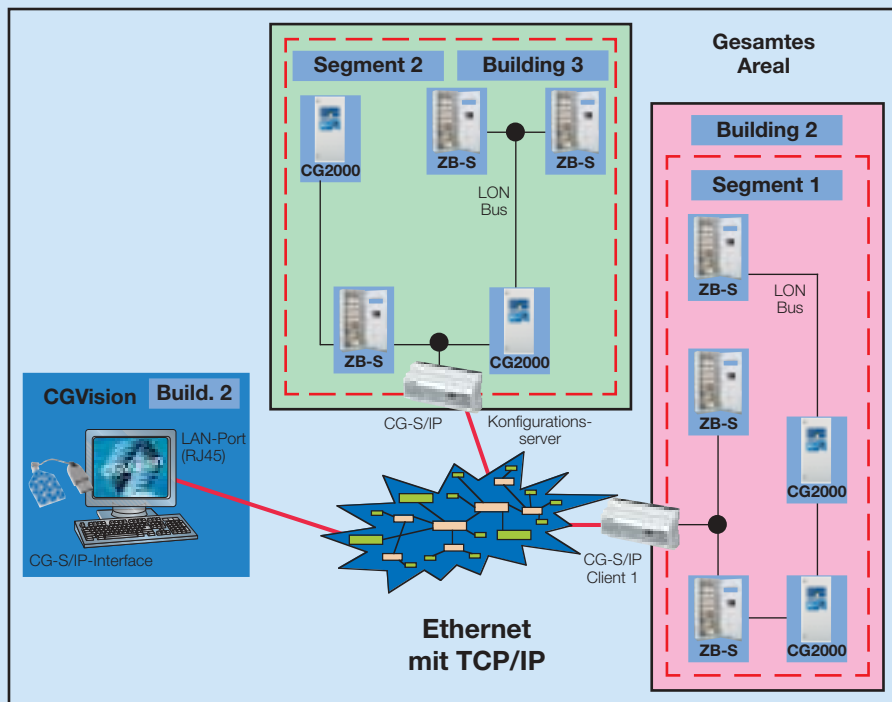

CGVision with EGA-Bus

Conventional EGA-Bus

Characteristics:

- up to 32 emergency light devices per line ZB96, Euro ZB.1, GVL 24.1 and CG 48
- max. 8 lines per device family possible (max. 256 devices)
- with > 2 lines: amplification card (COM-Ports) is necessary
- all topologies possible
- 1 device family per line
- recommended line: NYM 3 x 1.5 mm²

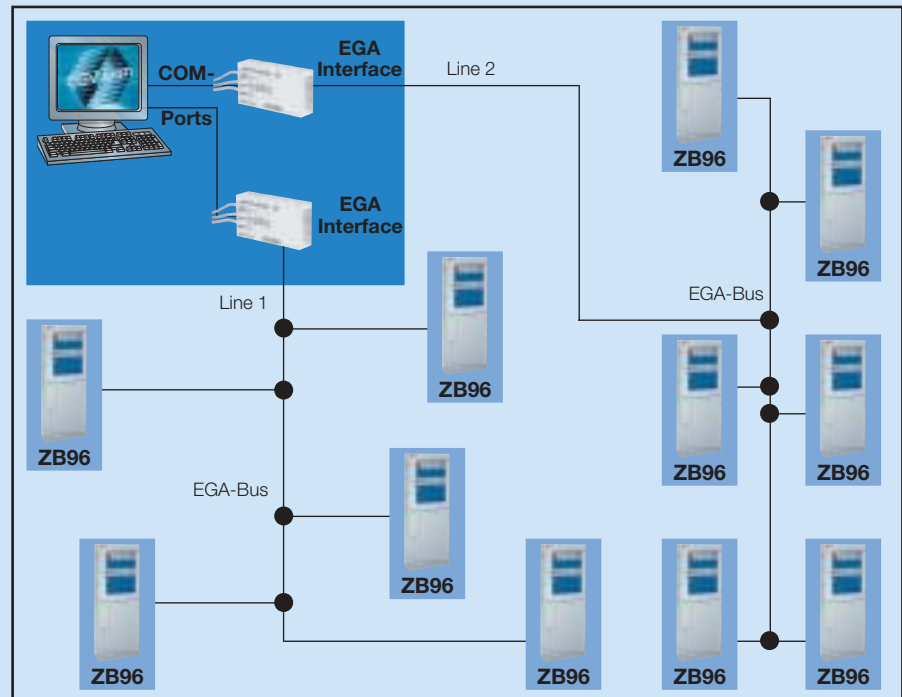

Within one Building

Characteristics:

- up to 32 emergency light devices per line ZB96, Euro ZB.1, GVL 24.1 and CG 48
- max. 8 lines per device family possible (max. 256 devices)
- EGA/Com-Server needs 24 V/DC supply
- all topologies possible
- 1 device family per line
- recommended cable: NYM 3 x 1.5 mm²

CGVision with EGA-Bus via Ethernet

